



BENTOBUILD

LATTICE SYSTEM
INSTALLATION
GUIDE

OVERVIEW

Introduction	04
Index of Parts	06

1

WEIGHT TOLERANCE GUIDELINES

Weight Loads	08
Bento's Preferred Wall	09
Other Wall Types	10

2

GETTING STARTED

List of Tools	11
Locating Your Assembly	12
2.1 Confirm Floor Surface	13
2.2 Check Floor is Level	13
2.3 Mark System Height	14
2.4 Mark System Width	15
2.5 Find Studs	15
2.6 Mark Top Ledger Height	16

3

CONNECT

3.1 Secure Top Ledger	17
3.2 Attach Leveling Feet	18
3.3 Hang Half Struts	19
3.4 Attach Remaining Ledgers	20

4

POSITION

4.1 Level All Directions	21
4.2 Fasten Bottom Ledger	22
4.3 Check if Struts are Plumb	23
Shimming	24
4.4 Fasten Remaining Struts	24
4.5 Align Struts	25

5

SECURE AND TIGHTEN

5.1 Screw in Remaining Ledgers	26
5.2 Tighten Hardware	27
5.3 Lower Leveling Feet	27
5.4 Attach Side Facias	28

OVERVIEW

Introducing the BentoBuild Lattice System

The **BentoBuild Lattice System** is a modular wall mounting system.

The grid-based Lattice System allows for the quick and easy mounting of modules to virtually any wall type. The system combines horizontal ledgers with vertical struts to maximize strength and flexibility.

The purpose of this guide is to provide an overview of the Lattice System and steps for assembly. For more detail about installing modules, see the BentoBuild Series 001 Installation Guide.

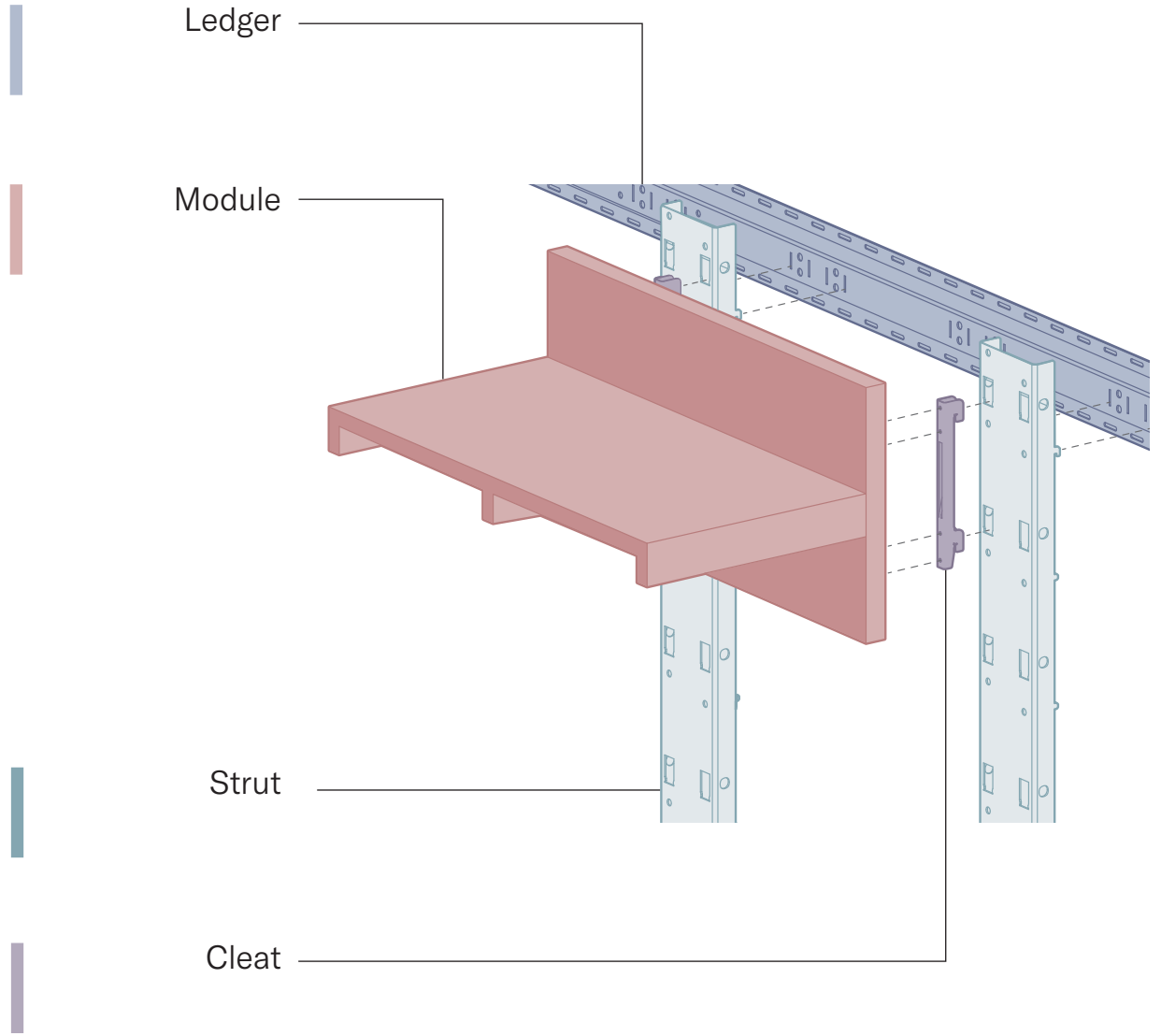

Index of parts

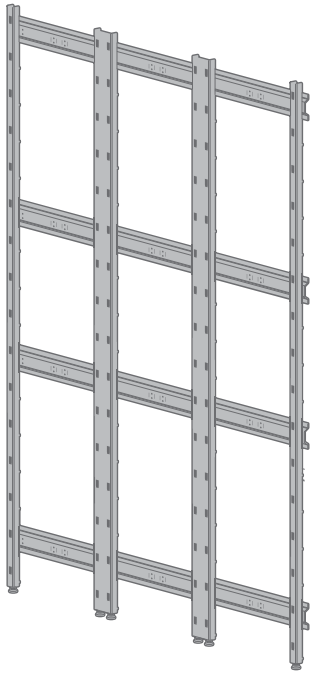

Our **Lattice System** is a system of struts, ledgers, and other components that create a modular mounting grid on a wall.

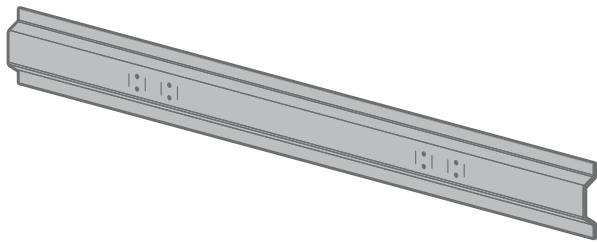

Ledgers are horizontal pieces that are attached directly to a wall.

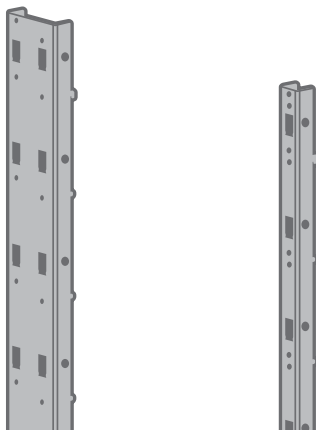

Struts are vertical pieces that hang off a ledger, which connect to cleats.

Half struts are useful where the Lattice System ends. Wider, full struts are used where modules meet in the middle of the Lattice System assembly.

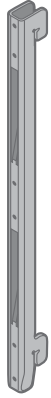

Cleats attach modules to the Lattice System.

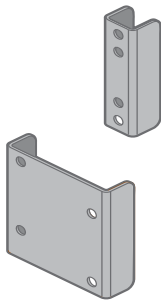

Strut connectors join struts together.

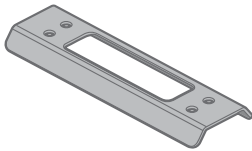

Ledger connectors join ledgers together.

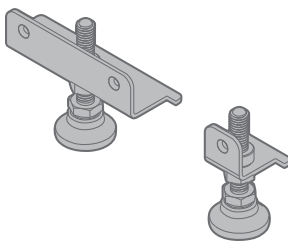

Leveling feet attach to the bases of struts, which enable them to stand on a floor surface and support heavy loads.

1

WEIGHT TOLERANCE GUIDELINES

Weight loads

Due to potential differences in wall construction, floor finish, hardware selection, and overall quality of Lattice System installation, Bento cannot specify loading restrictions for the Lattice System.

The Lattice System and associated modules are designed to support reasonable loads over the course of their lifetimes. Avoid overloading and unevenly loading modules. Only use modules for their intended purpose. We do not recommend standing or sitting on any part of the Lattice System, other than parts specifically designed by Bento for that purpose.

Bento is not responsible for the condition or strength of the wall or ensuring the Lattice System is mounted correctly. Similarly, Bento cannot be held liable for any failure to follow the specified guidelines.

Please refer to the BentoBuild Contractor's Guide and Series 001 Installation Guide for details on assembly.

Preferred wall type

The BentoBuild Lattice System can be attached to many different types of wall surfaces but, for ease of installation, we recommend $\frac{5}{8}$ " gypsum wall board over $\frac{1}{2}$ " OSB or plywood on wood or metal studs with a minimum of a level 2 finish wherever the BentoBuild Lattice System will be used.

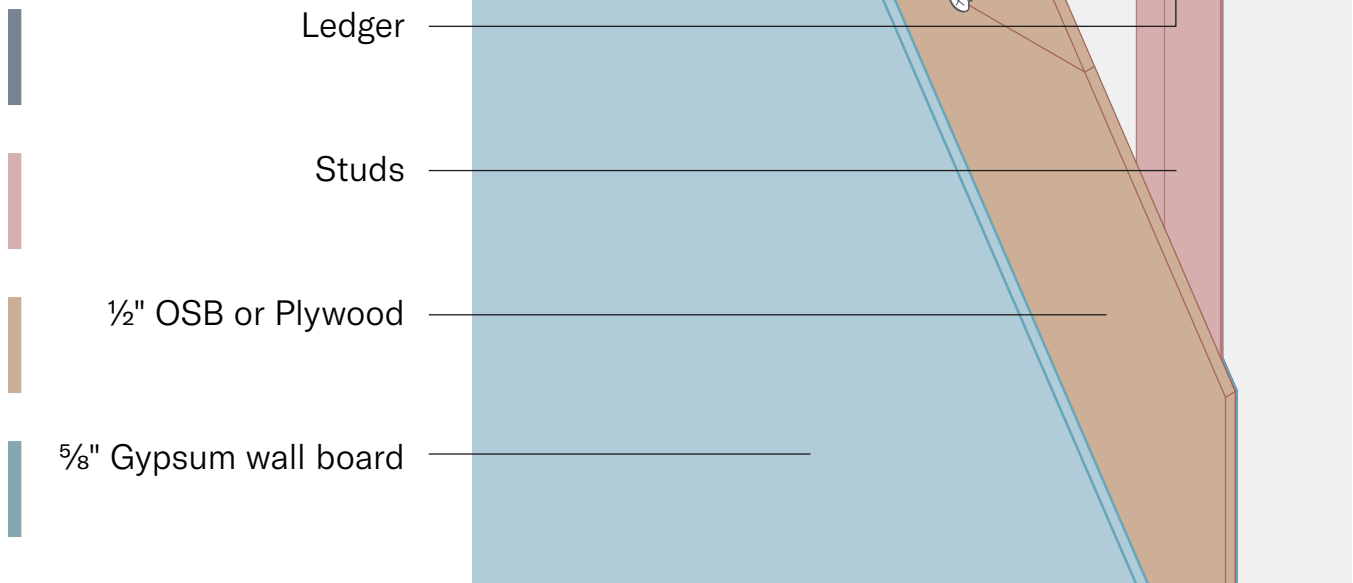

Other wall types

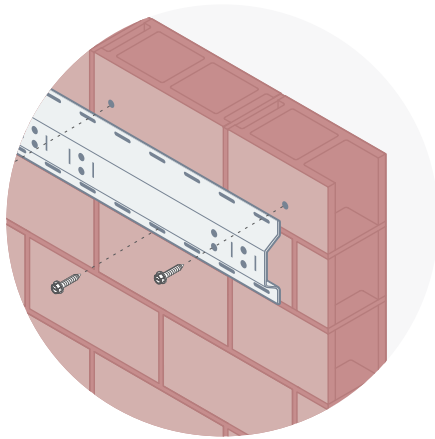

Solid wall

For masonry walls use $\frac{3}{16}$ " x 1- $\frac{1}{4}$ " Hex Tapcon concrete screws. These should be placed in a zig zag pattern top to bottom with roughly 12" spacing. Pre-drill pilot holes with $\frac{5}{16}$ " masonry bit using hammer drill. Screw concrete screws through ledger into pilot holes.

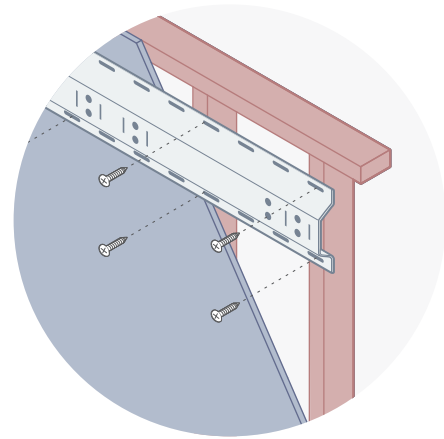

Wood or metal stud wall

Locate wall studs using a stud finder. Studs are typically 16" on center, measure 17 $\frac{3}{4}$ " from the edge of the wall then mark every 16" from there to find the center of the studs. Fasten the ledgers to every available stud using 8 1- $\frac{1}{2}$ " drywall screws and a drill.

2 GETTING STARTED

List of tools



$\frac{5}{32}$ " hex key



Drill w/ driver

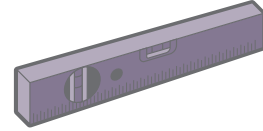

Bubble level

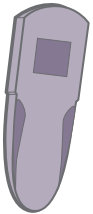

Stud finder

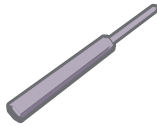

Screwdriver

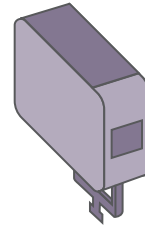

Laser level
(optional)



Box of appropriate
fasteners for wall type

Locating your assembly

The BentoBuild Lattice System is designed using a 6" vertical and 12" horizontal grid, and all modules are sized in 6" vertical and 12" horizontal increments. Our Lattice System is typically designed to start 5 1/2" off the ground or 3 1/2" for ADA applications. Lattice Systems may be placed at other heights but countertop locations will not be at code required heights.

The top ledger should be placed 2" lower than the top of grid.

Lattice assembly



Module assembly

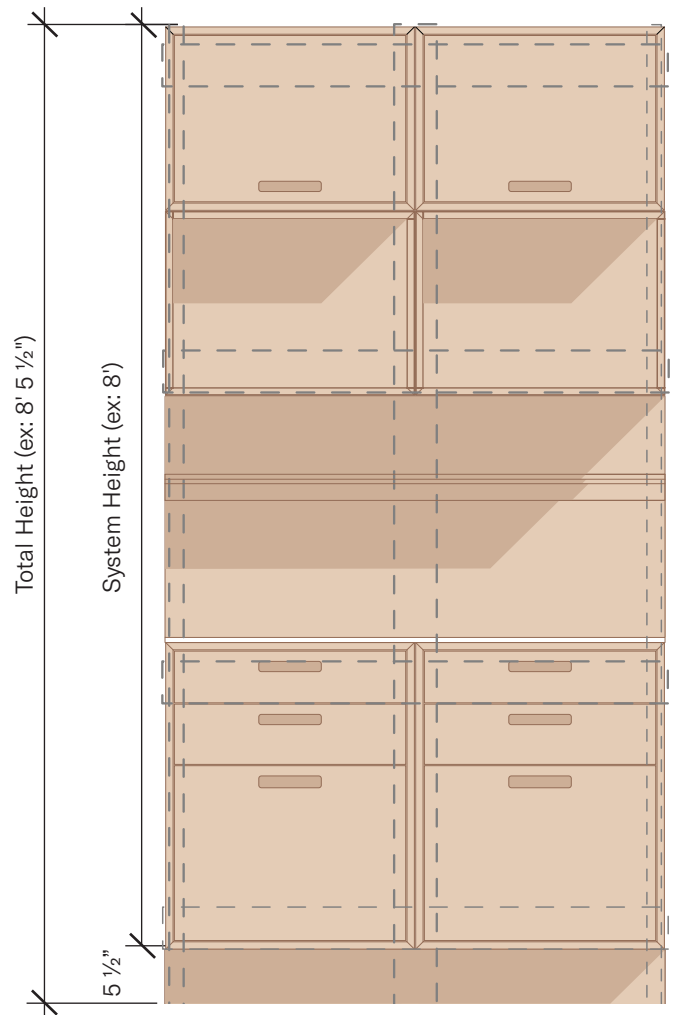
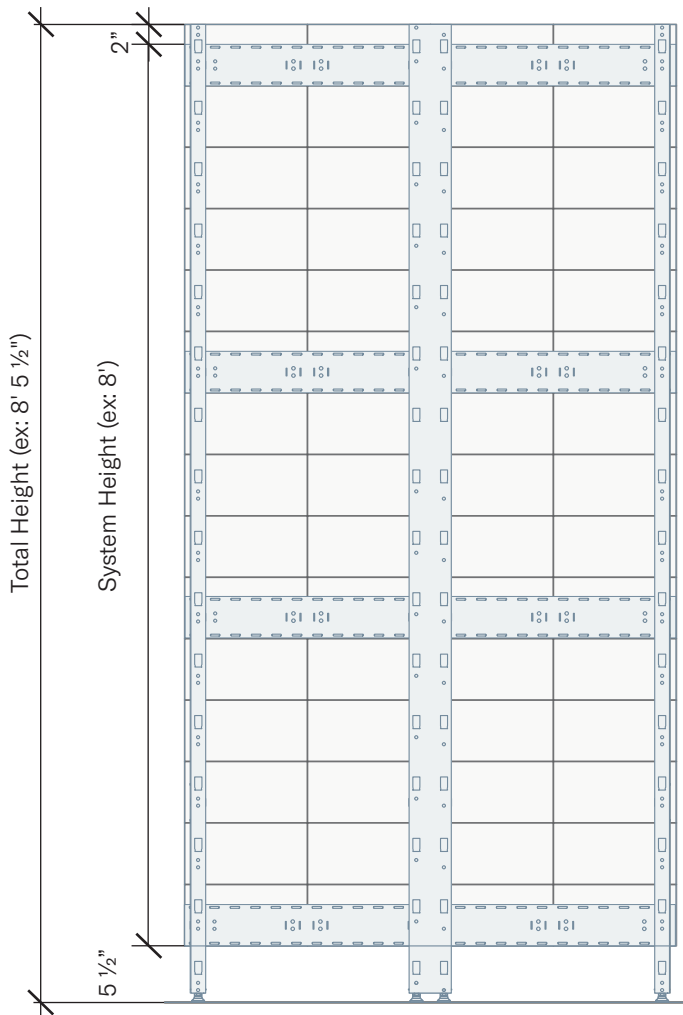

2.1 Confirm floor surface

First, confirm current floor surface is the final, finished surface. If the floor is not finished, take any height created by additional flooring material or finishing into account.

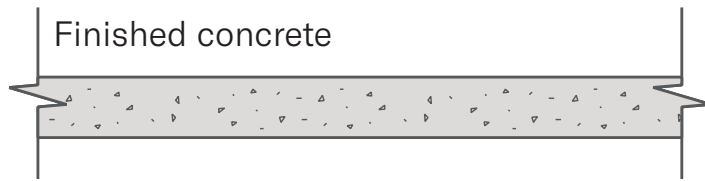
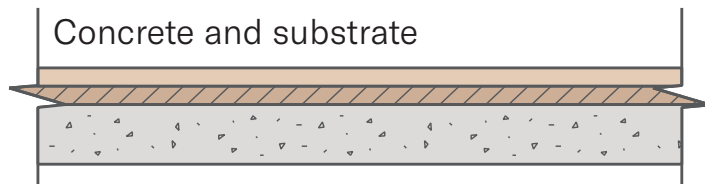
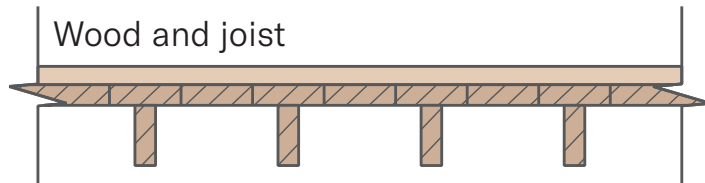

2.2 Check floor is level

Use a bubble level to gauge if floor is level prior to installation.

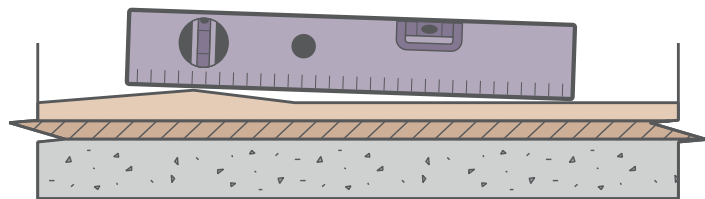

2.3 Mark Lattice System height

Using a bubble level, find the highest point of floor within the width of the Lattice System.

Next, based on provided drawing, mark the overall height of your system. Ensure your mark is level.

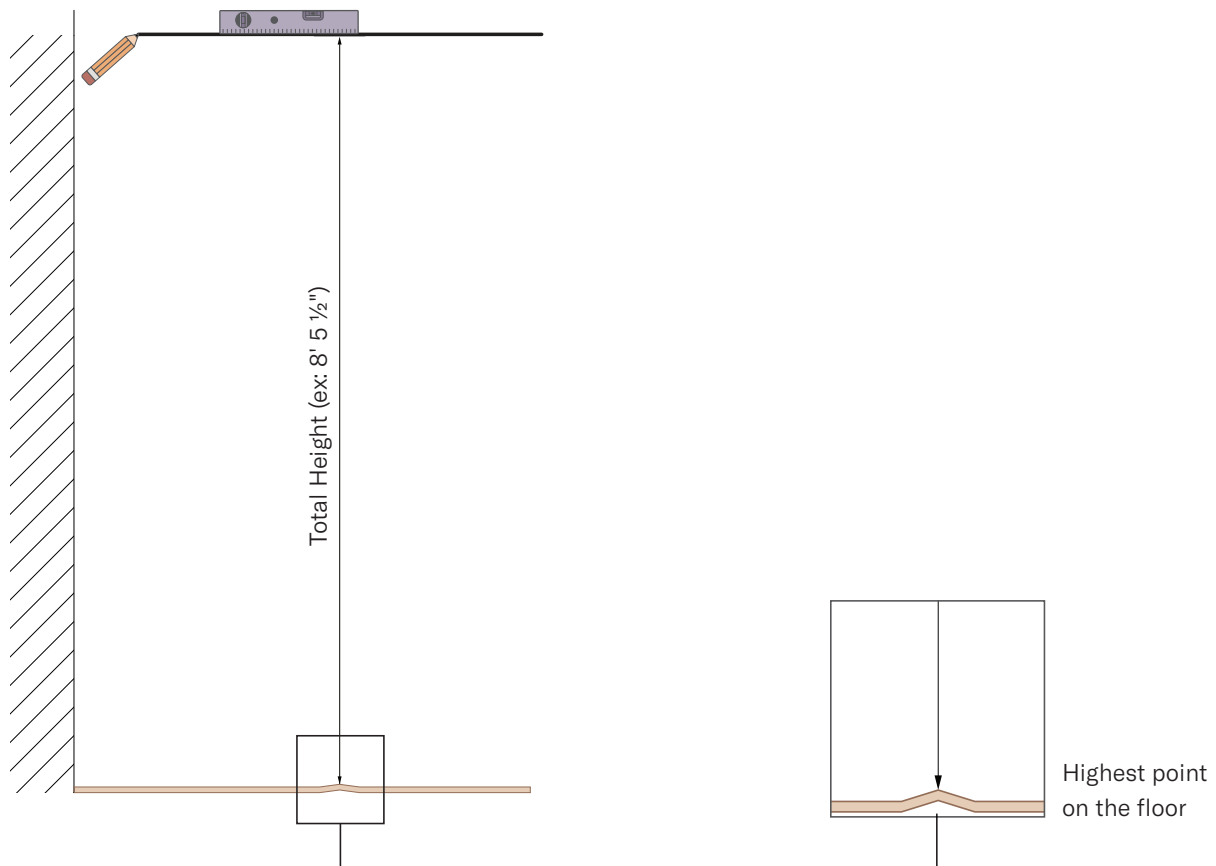

2.4 Mark Lattice System width

Based on provided drawing, mark out total width of the Lattice System at distance from specified wall.

Notes:

Make note of the extents of your system based on provided drawings. Make sure there are no conflicts that would prevent successful installation of the Lattice System.

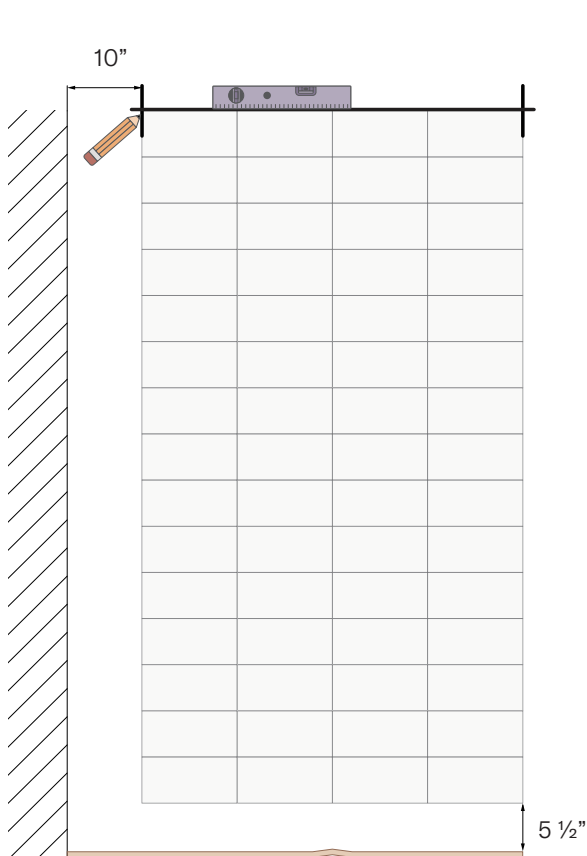

2.5 Find studs

Locate and mark out all the studs using a stud finder.

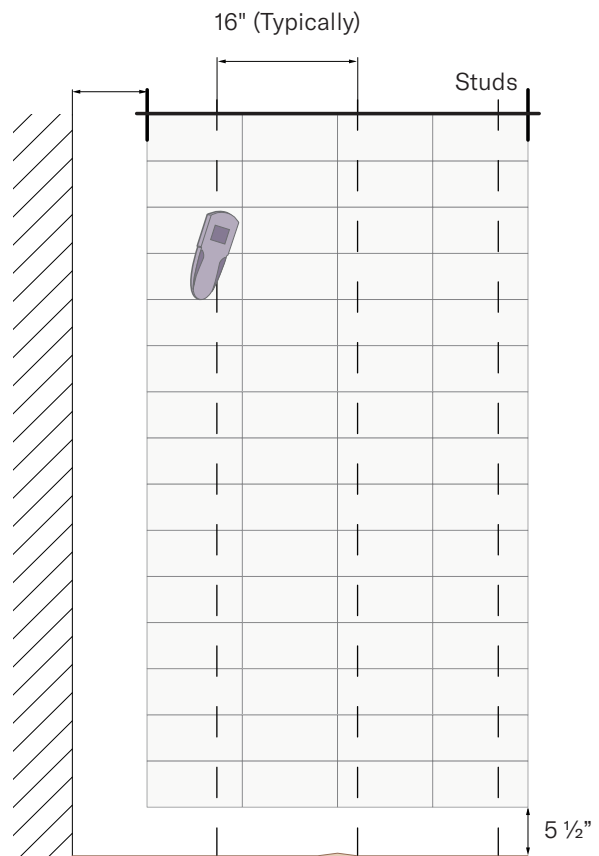

2.6 Mark top ledger height

The top edge of the highest ledger should be placed 2" lower than the top of your system. Use a laser level, if possible, for added accuracy.

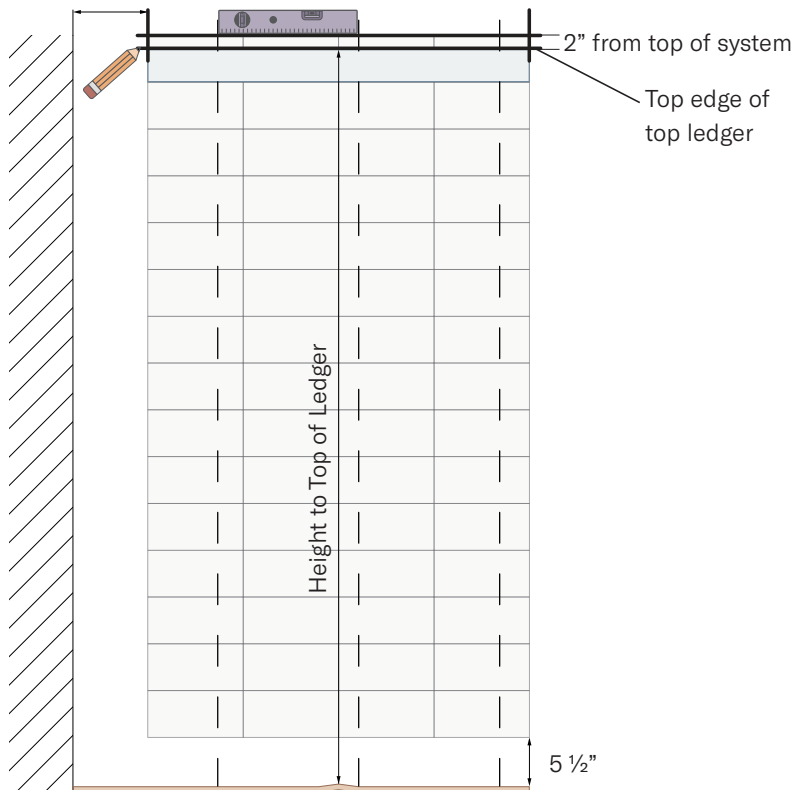

3 CONNECT

3.1 Secure top ledger

A. Loosely fasten top ledger into the wall using 4 screws in marked studs.

B. Note:

If necessary, use ledger connectors to continue attaching additional ledgers until all ledgers have been attached as per provided drawing.

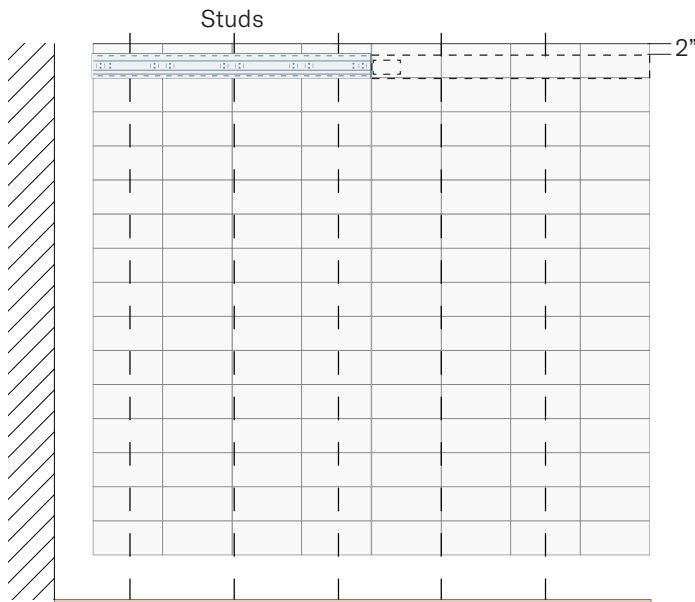

A.

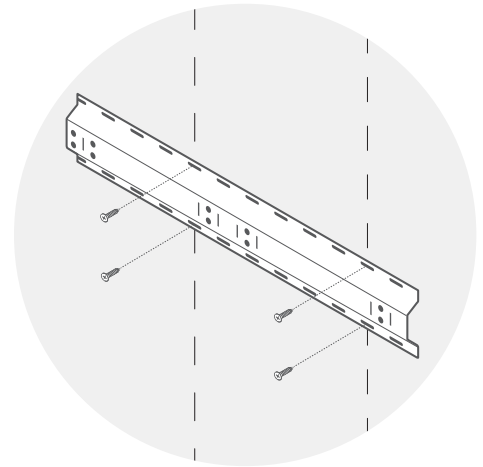

B.

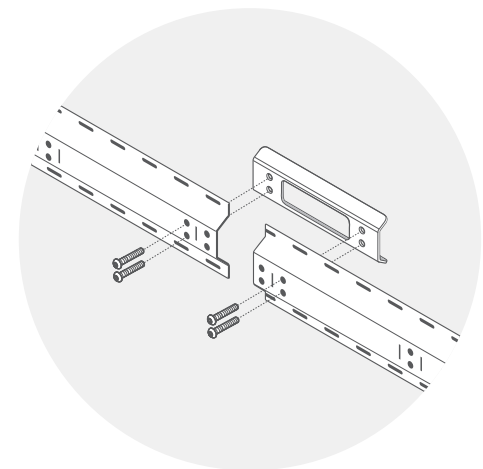

3.2 Attach leveling feet

Attach leveling feet to the two half struts.
 Make sure distance from the bottom of
 each foot to base of strut is preset to ½”.

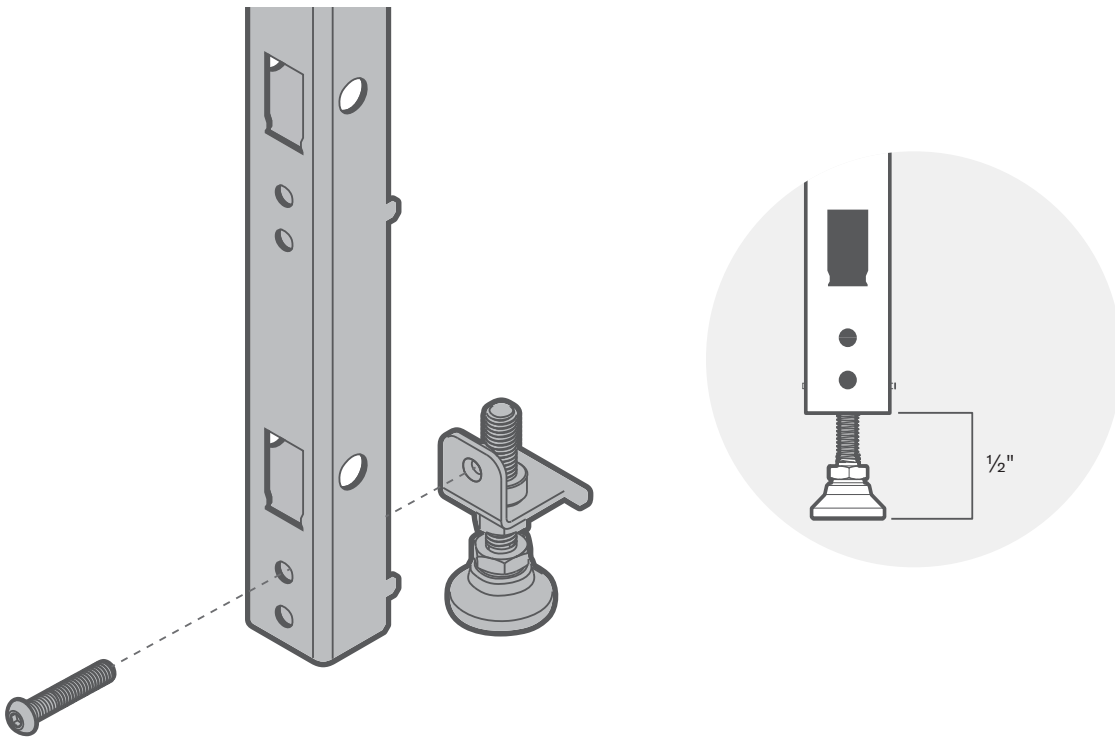

3.3 Hang half struts

Hang one half strut at either end of Lattice System using hooks. Secure to ledger with hardware provided and lightly tighten.

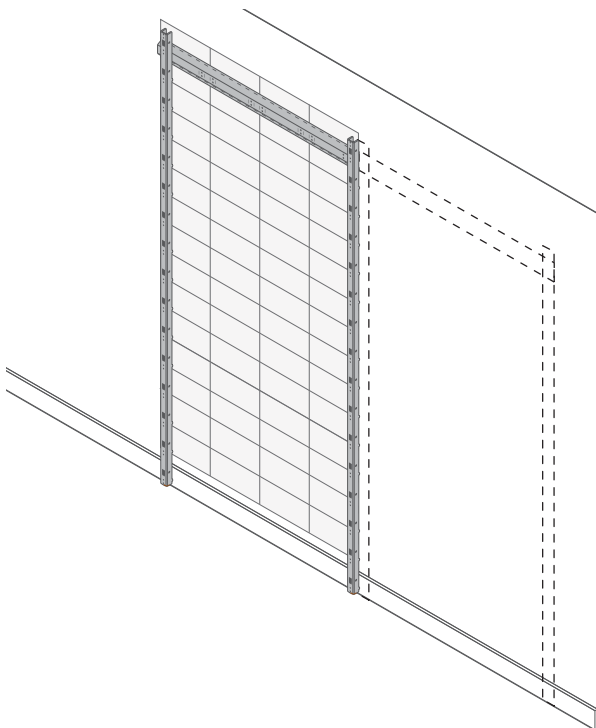
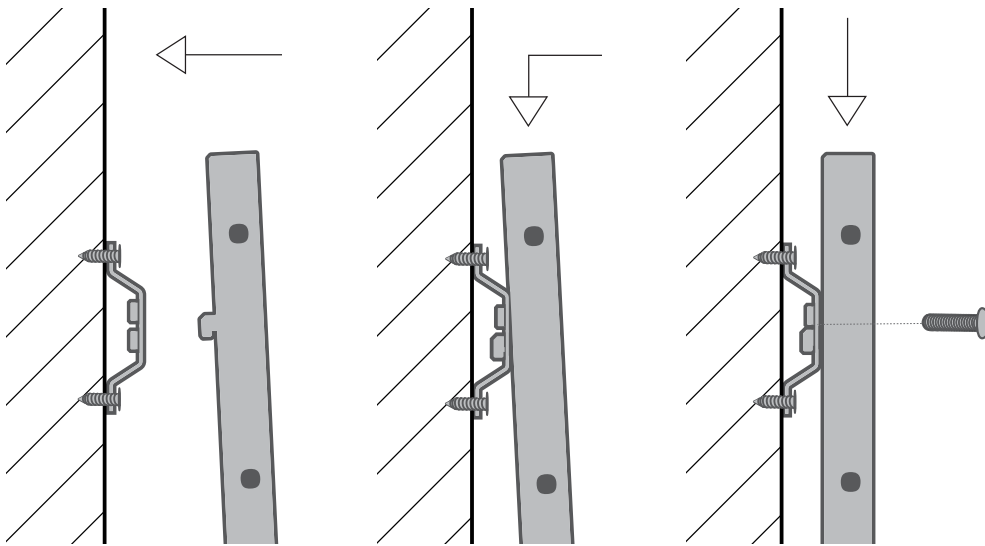

Note:

If using ledger connectors, hang full strut at intersection of ledgers.

3.4 Attach remaining ledgers

Attach remaining ledgers, screwing them into the half struts.

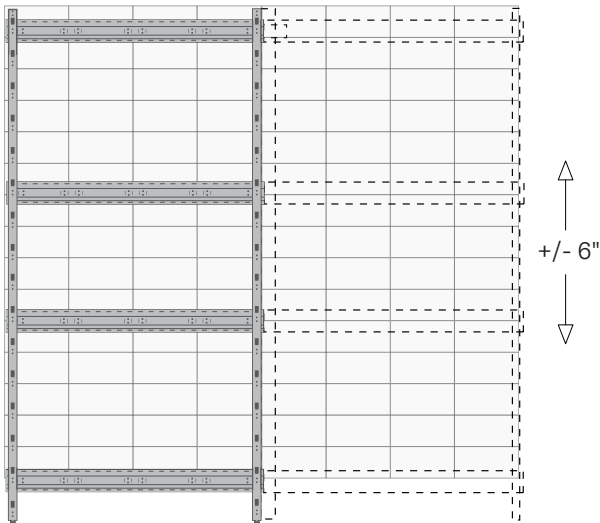
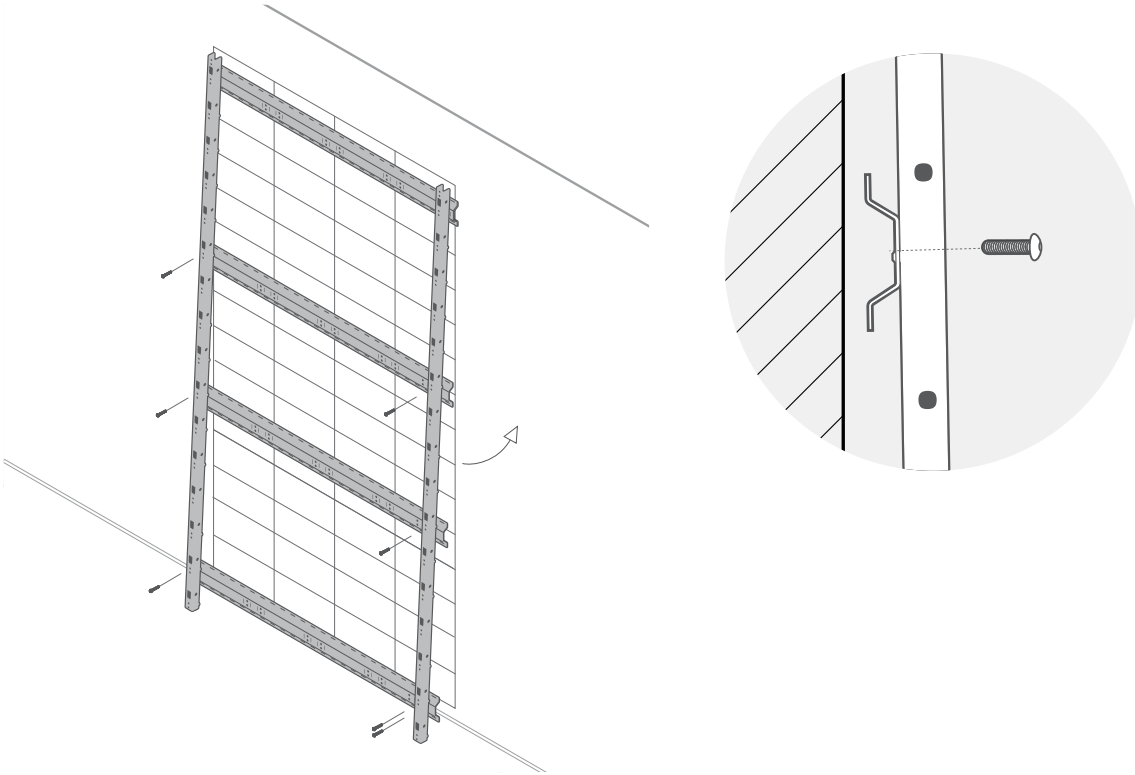

Note:

If using ledger connectors, connect to full struts to support additional ledgers at each intersection.

4 POSITION

4.1 Level all directions

- A. Check if Lattice System is square using a bubble level along side of strut.
- B. If Lattice System is not square, sway struts from side to side until square.

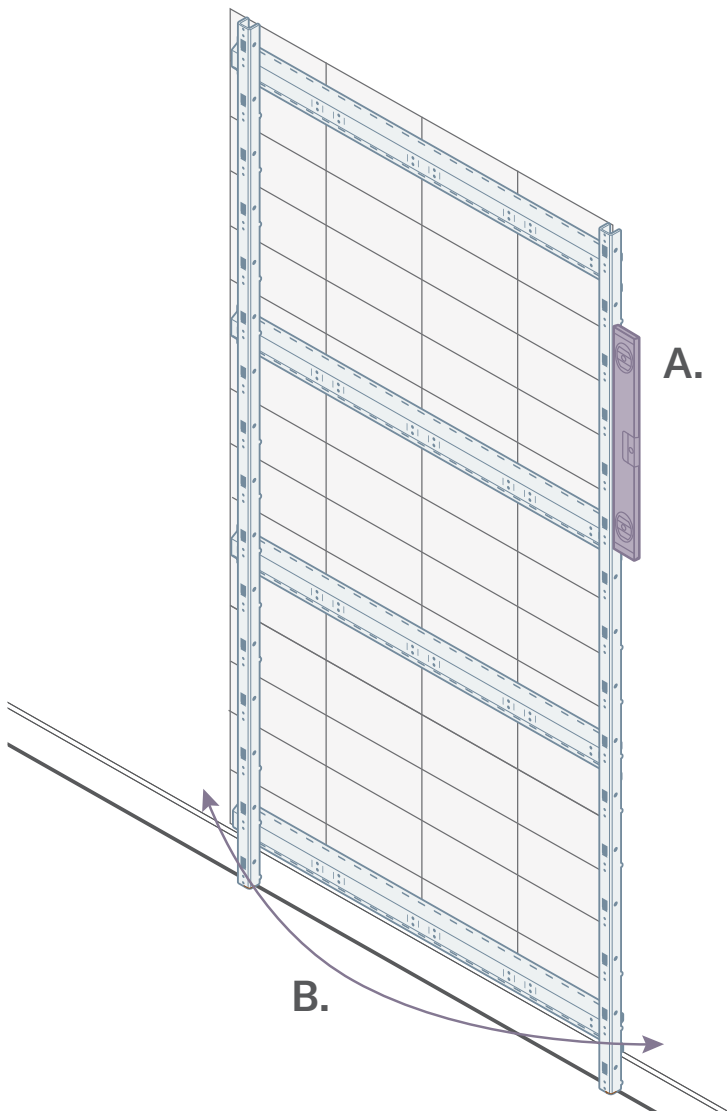

4.2 Fasten bottom ledger

Loosely fasten bottom ledger to the wall with positioning screws, as close to the strut locations as possible.

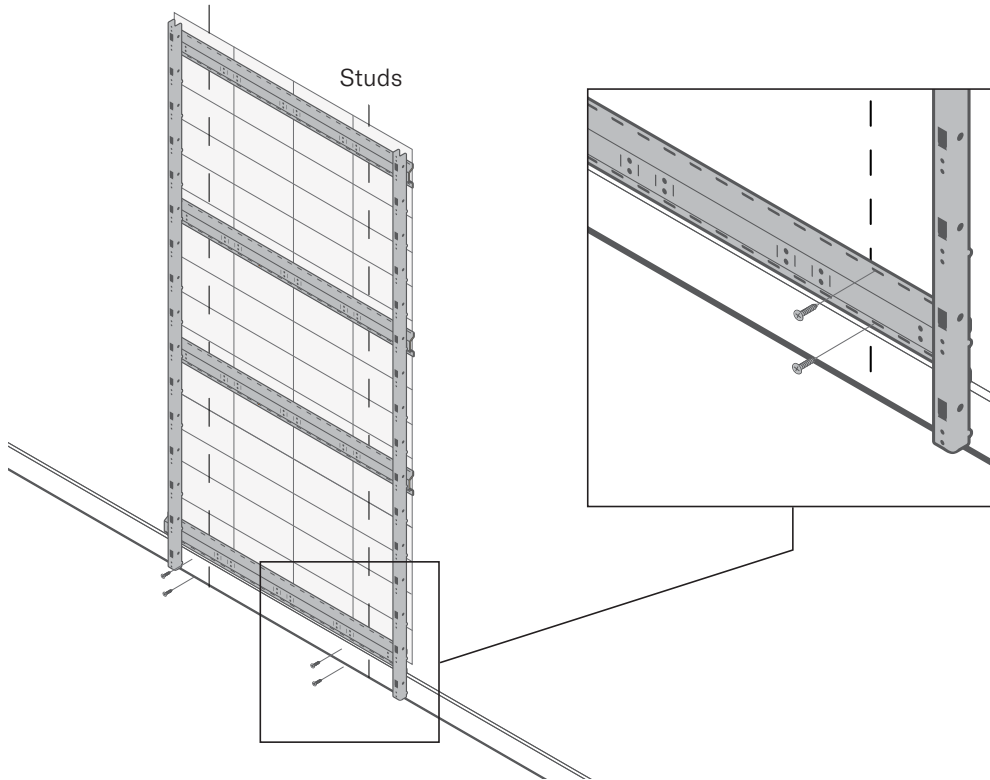

4.3 Check if struts are plumb

Check if struts are plumb using bubble level on front face of struts.

Note:

If Lattice System is not plumb, insert shims until plumb.

Refer to pg. 24, "Shimming", for further instructions on shimming.

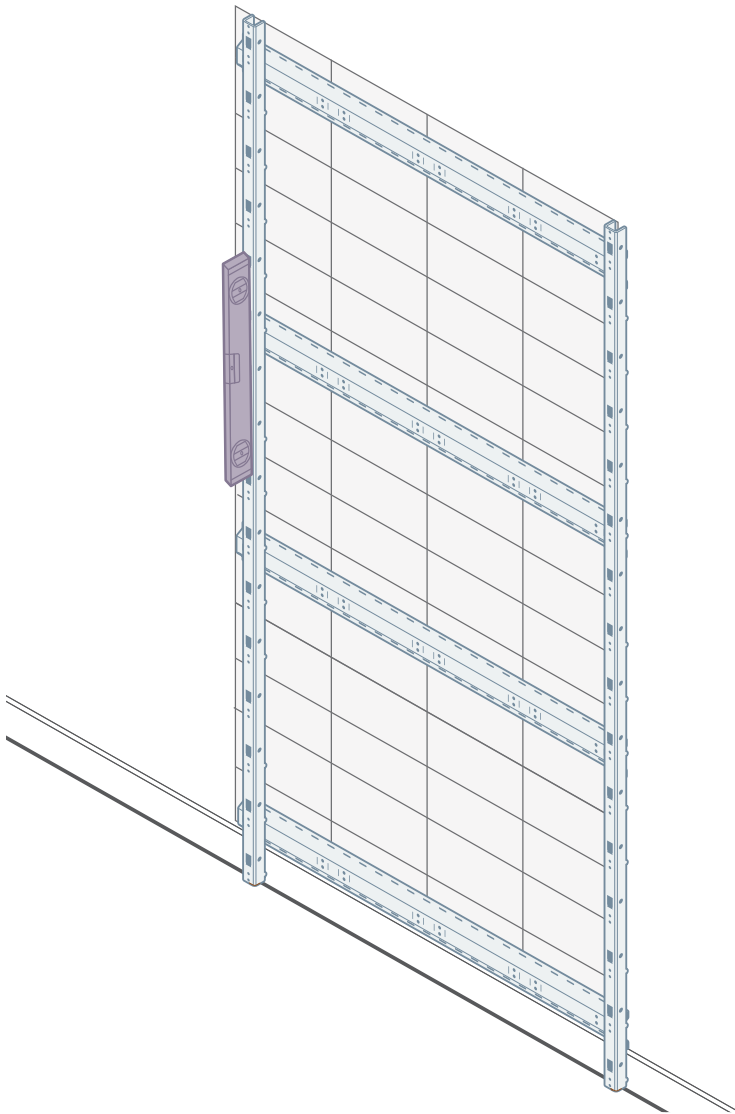

Shimming



If any strut is out of alignment, add shims behind ledgers near affected Struts.

Inserting shims

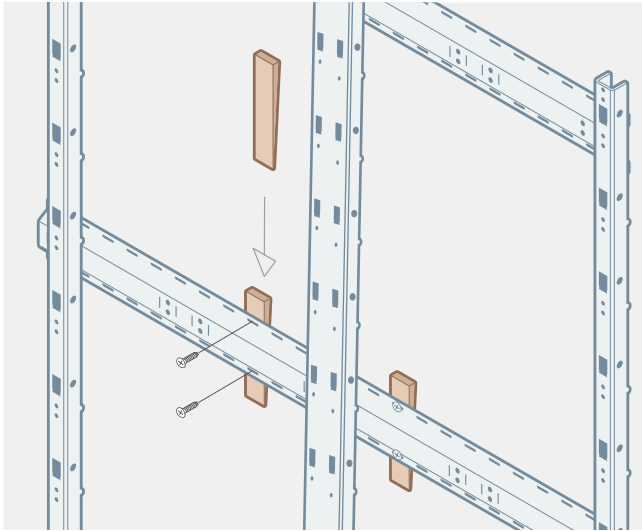

Ideal wall (no shims)

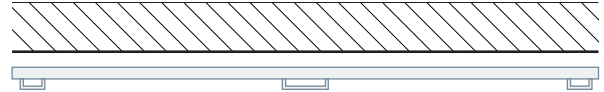

Uneven walls (shims)

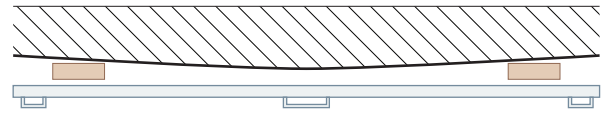

Section of shimmed wall

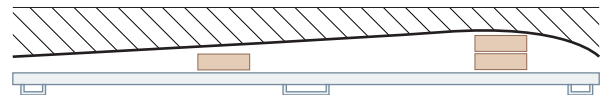
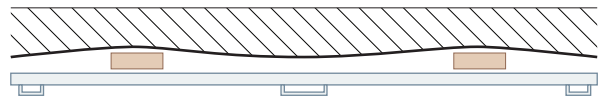
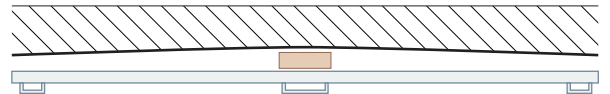
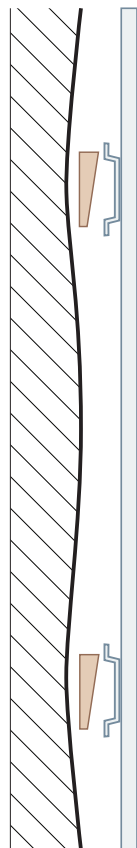

4.4 Fasten remaining struts

Based on provided drawings, fasten remaining struts to ledgers with hardware provided and lightly tighten.

Note:

If you added full struts, rearrange or remove to match provided drawings.

4.5 Align struts

Using a strut or long straight edge for reference, check if front faces of all struts are planar. Add shims to all ledgers if not planar.

Refer to pg. 24, "Shimming", for further instructions on shimming.

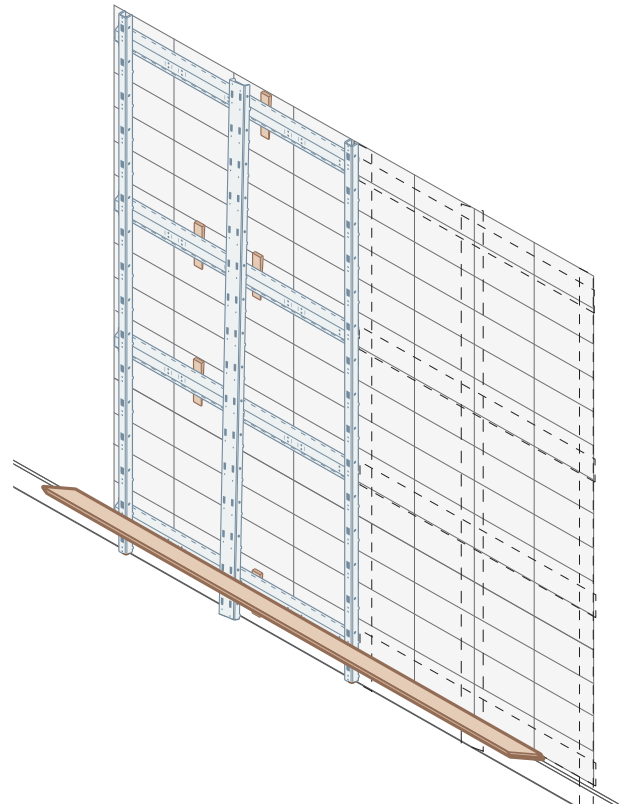
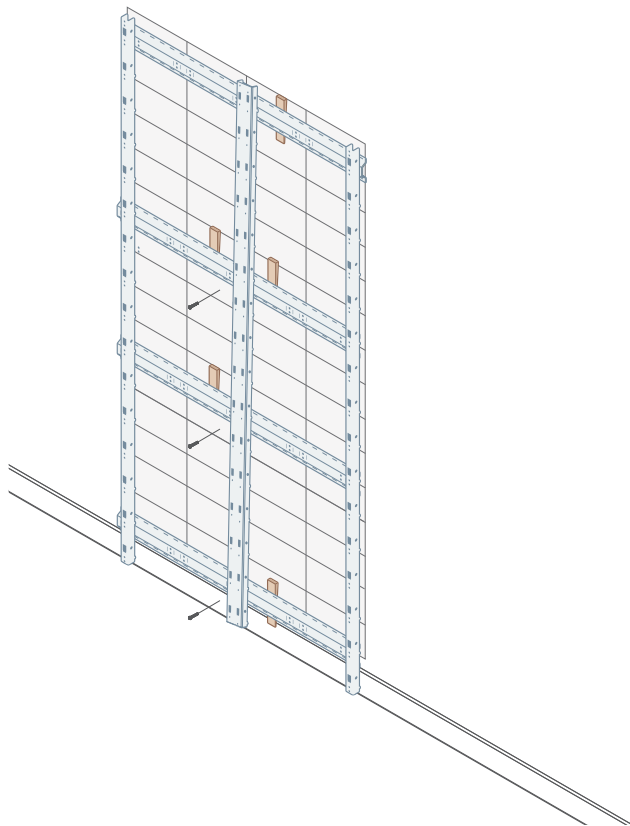

5 SECURE AND TIGHTEN

5.1 Screw in remaining ledgers

- A. Screw remaining ledgers into wall at stud locations every 16" through upper and lower slots of ledger.
- B.

Note:

Tightly fasten top and bottom ledgers to wall. Refer to Steps 3.1 and 4.2.

For shimming top and bottom ledgers, refer to pg. 24, "Shimming", for further instructions on shimming.

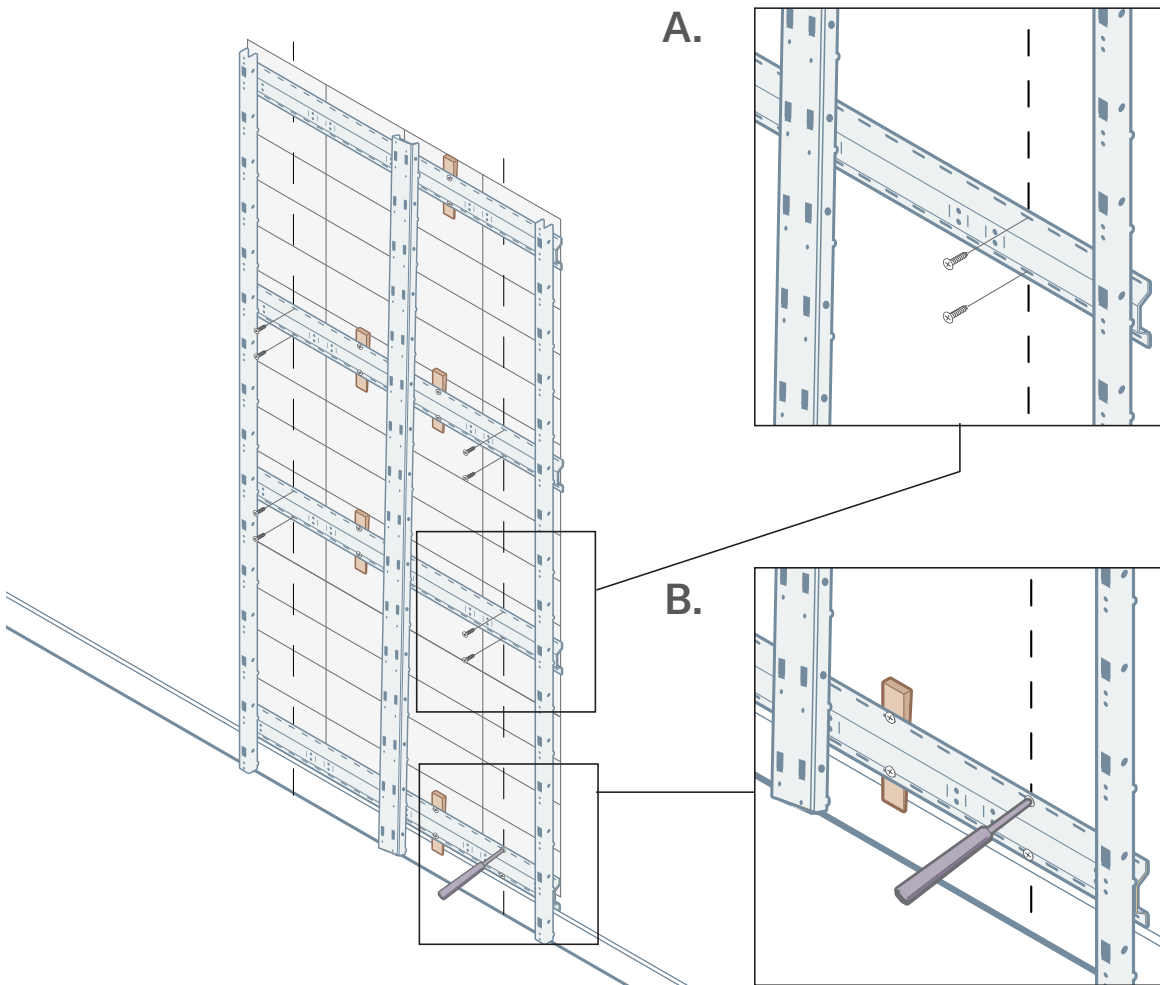

5.2 Tighten hardware

Make sure all remaining hardware is in place. Tighten struts to ledgers.

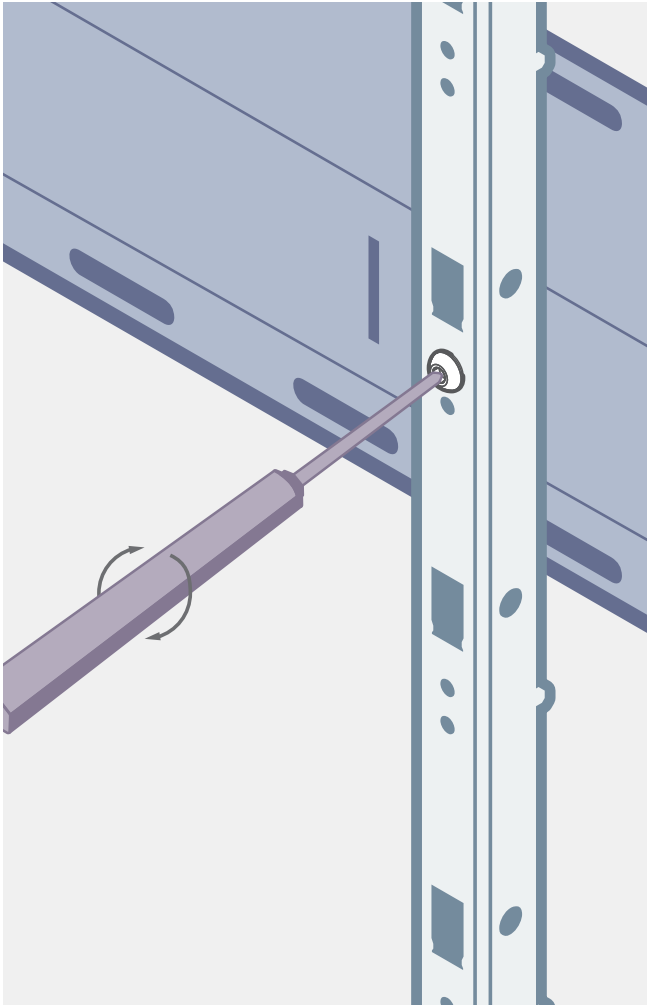

5.3 Lower leveling feet

Lower leveling feet down to the floor.

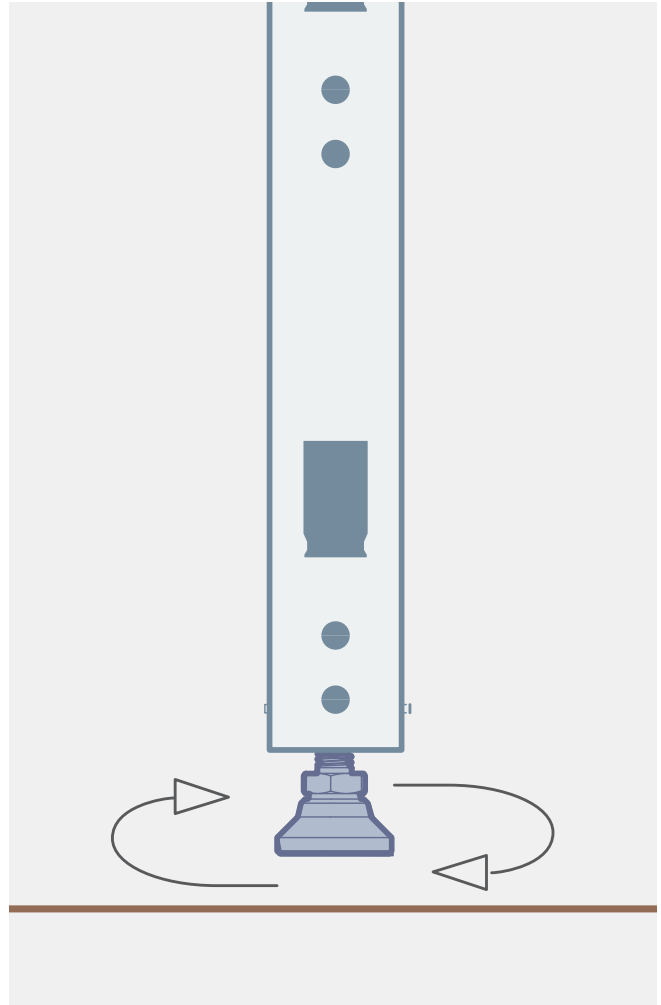

5.4 Attach side facias

Attach side facias to half struts using corresponding hardware.

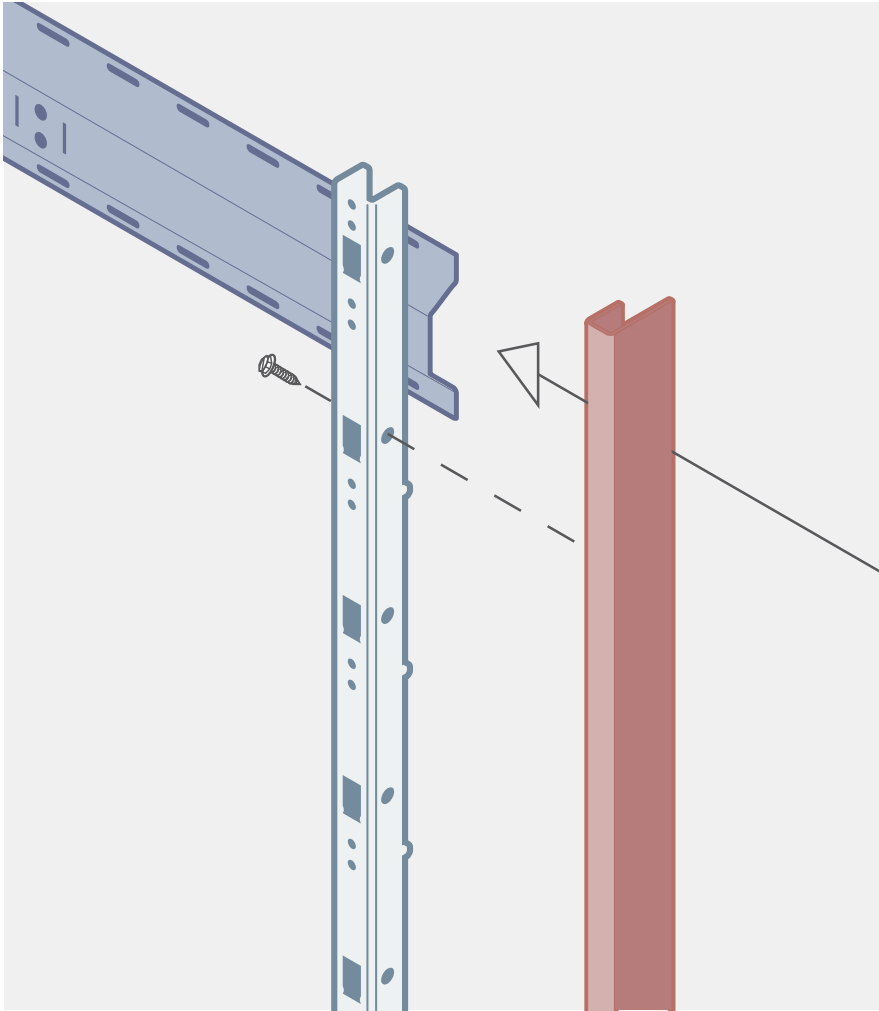

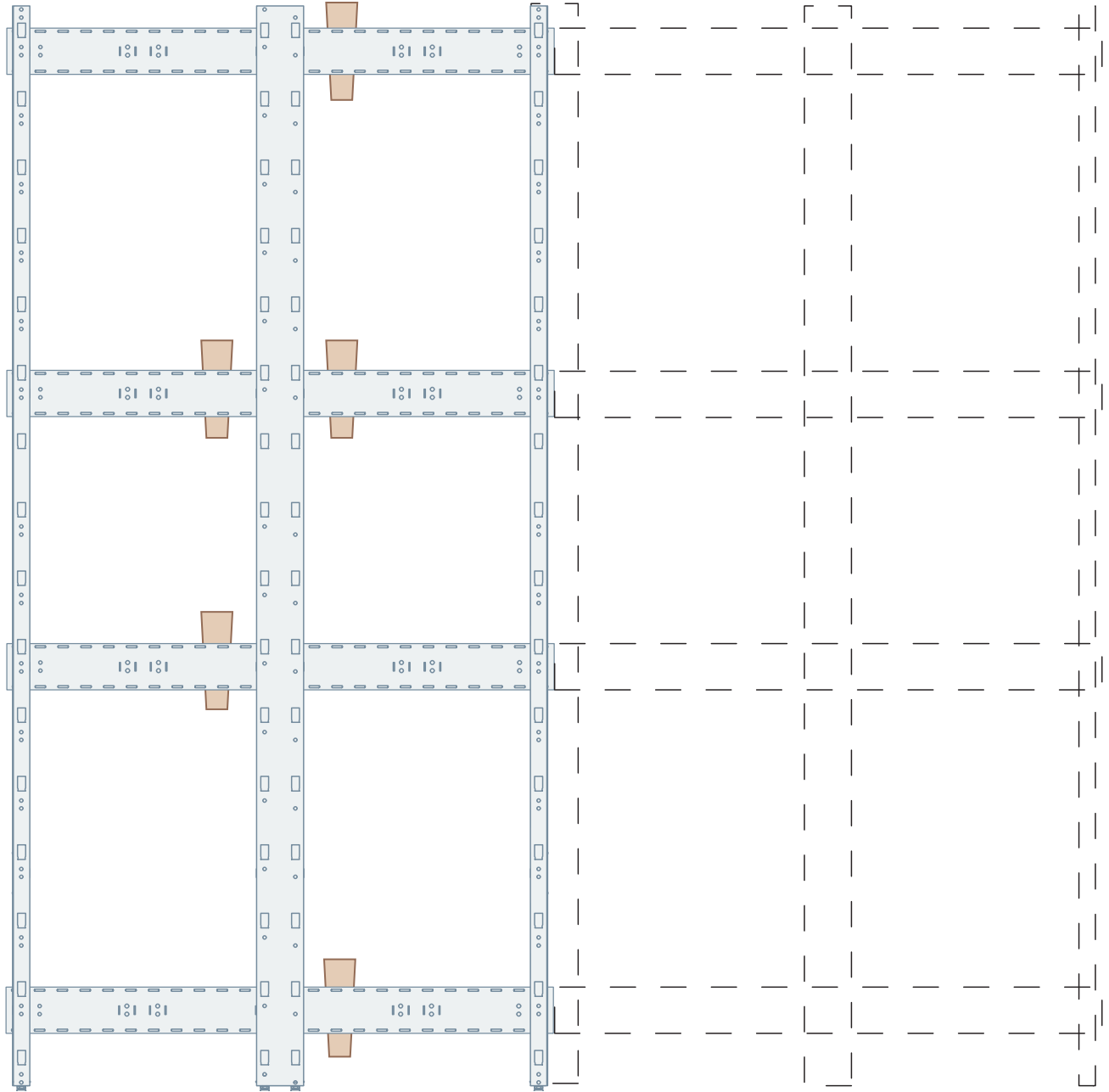

Further reading

Please move on to the BentoBuild Series 001 Installation Guide to continue the installation of your system.



BENTOBUILD

BentoBuild
254 36th Street
Floor 6, Suite C663
Brooklyn, NY 11232

o +1 718.260.8200
BentoBuild.com